

Hardware Manual

1240i

Programmable Step Motor Driver

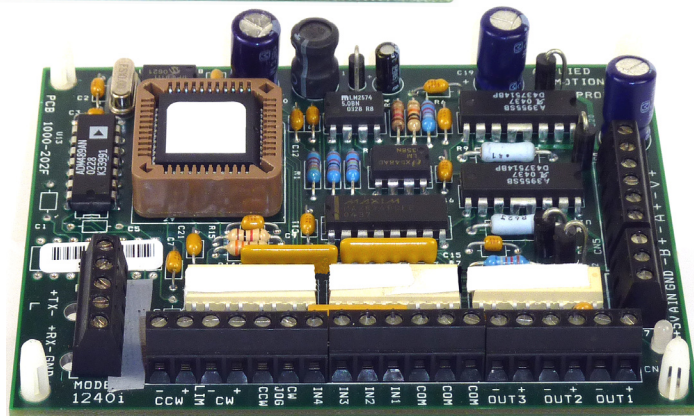
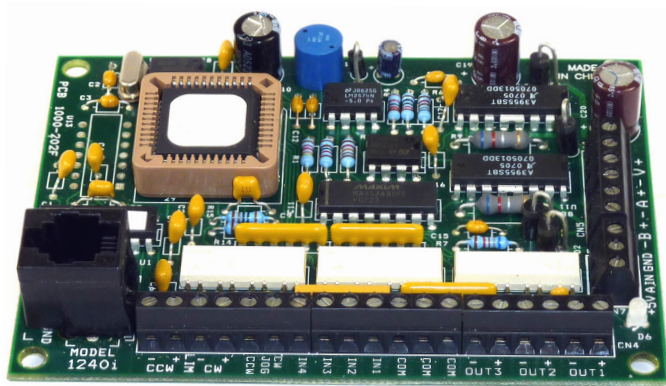

**Applied
Motion
Products**

motors • drives • controls

Table of Contents

Introduction	4
Features	4
Block Diagram	4
Getting Started	5
Connecting the Power Supply	6
Power LED Diagnostics	6
Choosing a Power Supply	7
Connecting the Motor	8
Connecting to the PC	9
Jogging	10
Limit Switches	10
Wiring a Mechanical Limit Switch	11
Wiring a Limit Sensor	11
Wiring Inputs	12
Wiring Outputs	14
Microstepping	15
Mounting the Drive	16
Mounting the Optional MMI	17
Recommended Motors	19
Mechanical Outline	20
Technical Specifications	21
Mechanical Outline - Optional MMI	22

Introduction

Thank you for selecting an Applied Motion Products motor control. We hope our dedication to performance, quality and economy will make your motion control project successful. If there's anything we can do to improve our products or help you use them better, please call or fax. We'd like to hear from you. Our phone number is (800) 525-1609 or you can reach us by fax at (831) 761-6544.

Features

- Precise pulse width modulation switching amplifiers providing up to 1.2 amps per phase and microstepping to 50,800 steps per revolution.
- Accepts 12 - 42 VDC power supply.
- Powerful, flexible, easy to use indexer.
- Connects by a simple cable to your PC for programming (cable included).
- Microsoft Windows™-based software for easy setup and programming
- Eight inputs for interacting with the user and other equipment.
- Three outputs for coordinating external equipment.
- External trigger I/O is optically isolated, 5-24V, sinking or sourcing signals.
- PC/ MMI port is RS-232.
- 3.0 x 4.0 x 0.65 inch overall dimensions.
- Optional man machine interface (MMI) allows operator to enter distances, speeds, cycle counts and more.
- CE Compliant

Block Diagram

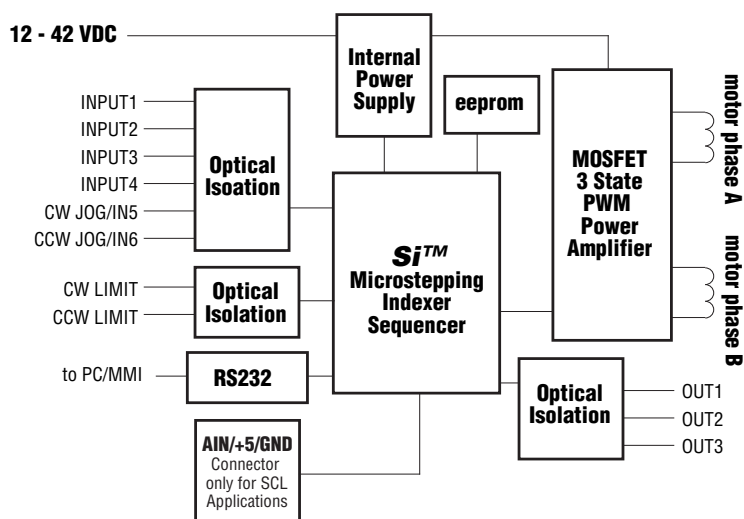

Getting Started

To use your 1240i motor control, you will need the following :

- a power supply (see page7 for help choosing one).
- a compatible step motor (see page 19 for recommended motors).
- a small flat blade screwdriver for tightening the connectors - an Applied Motion Products screwdriver suitable for this purpose is included with your drive.
- a personal computer running Windows 3.1, 95, 98, NT, W2K, XP, Vista or Vista64 or Windows7 with a 9 pin serial port (486 or better with 8 MB ram recommended)
- the Si Programmer™ software that came with your 1240i
- the programming cable that came with your 1240i
- Si Programmer™ software manual - on the CD that came with your 1240i

The sketch below shows where to find the important connection and adjustment points. Please examine it now.

There are two versions of the 1240i, one has an added 3-pin connector CN7.

All Mating connectors included.

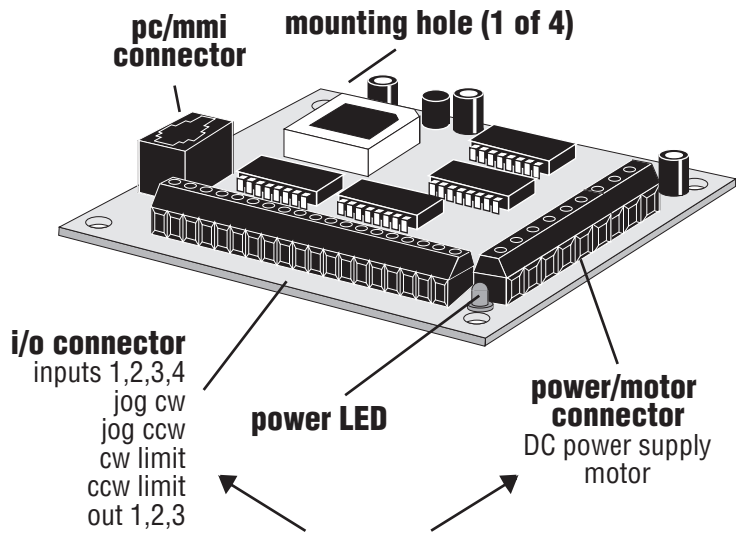

* Always use the blue & white Applied Motion screwdriver with these connectors. Larger screwdrivers may remove the plastic dimples that prevent the screws from falling out.

Connecting the Power Supply

If you need information about choosing a power supply, please read *Choosing a Power Supply* on the next page.

If your power supply does not have a fuse on the output or some kind of short circuit current limiting feature, you need to put a 1 amp fast acting fuse between the drive and the power supply. Install the fuse on the + power supply lead.

Connect the motor power supply as shown below. Use no smaller than 18 gauge wire. Be careful not to reverse the wires. Reverse connection may destroy your driver, void your warranty and generally wreck your day.

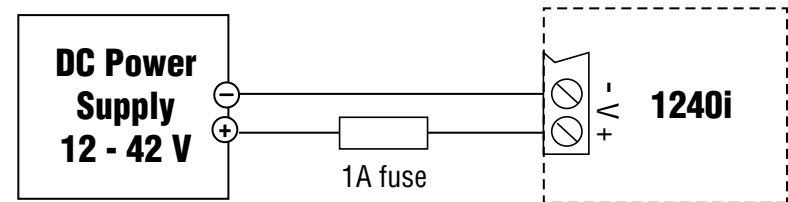

Power LED Diagnostics

The power LED is also used as a status indicator for alarm codes for the drive. Alarm codes are shown below:

Code:

2 red, 1 green
 2 red, 2 green
 1 red, 3 green
 2 red, 3 green
 4 red, 3 green
 7 red, 1 green
 solid red

Message:

ccw limit
 cw limit
 subroutine stack overflow
 subroutine stack underflow
 bad instruction in Si program (memory or software error)
 serial communication error
 firmware re-flash mode. Si Firmware Downloader can be used to recover drive, contact technical support.

Choosing a Power Supply

Please follow the recommendations below for choosing a power supply:

Voltage

Chopper drives like the 1240i work by switching the voltage to the motor terminals on and off while monitoring current to achieve a precise level of phase current. To do this efficiently and silently, you'll want to have a power supply with a *voltage rating at least five times that of the motor*. Depending on how fast you want to run the motor, you may need even more voltage than that. If you choose an unregulated power supply, do not exceed 28 volts. This is because unregulated supplies are rated at full load current. At lesser loads, like when the motor's not moving, the actual voltage can be up to 1.4 times the rated voltage. For smooth, quiet operation, a lower voltage is better.

Current

The maximum supply current you could ever need is the sum of the two phase currents. However, you will generally need a lot less than that, depending on the motor type, voltage, speed, and load conditions. That's because the 1240i uses switching amplifiers, converting a high voltage and low current into lower voltage and higher current. The more the power supply voltage exceeds the motor voltage, the less current you'll need from the power supply. A motor running from a 24 volt supply can be expected to draw only half the supply current that it would with a 12 volt supply. We recommend the following selection procedure:

- 1) If you plan to use only a few drives, get a power supply with at least twice the rated phase current of the motor.
- 2) If you are designing for mass production and must minimize cost, get one power supply with more than twice the rated current of the motor. Install the motor in the application and monitor the current coming out of the power supply and into the drive at various motor loads. This will tell you how much current you really need so you can design in a lower cost power supply. If you plan to use a regulated power supply our PS50A24 is a good choice.

Connecting the Motor

Never connect or disconnect the motor to the driver when the power is on.



Insulate unused motor leads separately, and then secure.
Never connect motor leads to ground or to a power supply.

You must now decide how to connect your motor to the drive.

Four lead motors can only be connected one way. Please follow the sketch at the right.

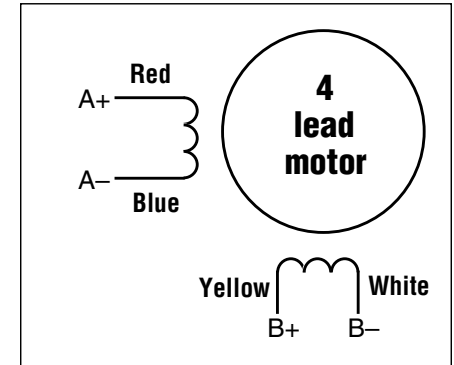

4 Leads

Six lead motors can be connected in series or center tap. In series mode, motors produce more torque at low speeds, but cannot run as fast as in the center tap configuration. In series operation, the motor should be operated at 30% less than the rated current to prevent overheating. Wiring diagrams for both connection methods are shown below.

Note: NC means not connected to anything.

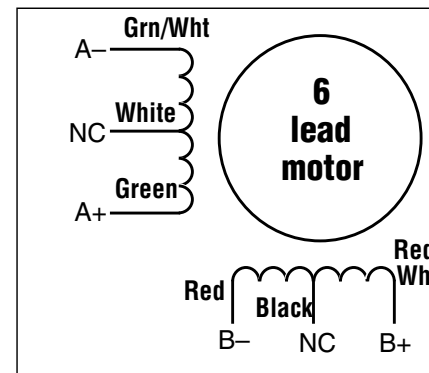

6 Leads Series Connected

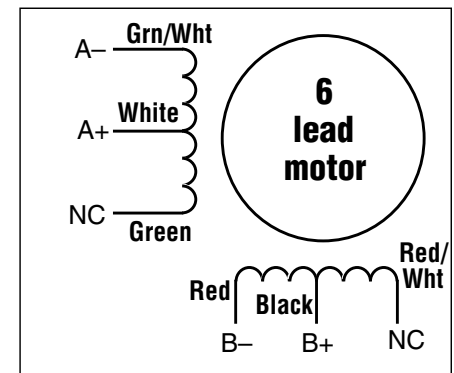

6 Leads Center Tap Connected

Eight lead motors can also be connected in two ways: series and parallel. As with six lead motors, series operation gives you more torque at low speeds and less torque at high speeds. In series operation, the motor should be operated at 30% less than the rated current to prevent overheating. The wiring diagrams for eight lead motors are shown below.

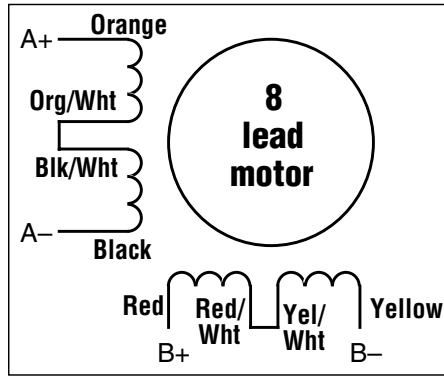

8 Leads Series Connected

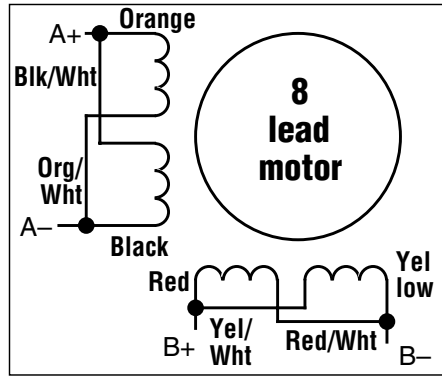

8 Leads Parallel Connected

Connecting to the PC

- Locate your computer within 6 feet of the 1240i. Connect the drive to your PC using the programming cable supplied.



Never connect the 1240i to a telephone circuit. It uses the same connectors and cords as telephones and modems, but the voltages are not compatible.

Programming Note: Always apply power to the 1240i after the Si™ Programmer software is running on your PC.

Jogging

Two of the 1240i input terminals are provided for jogging the motor. The inputs are labeled “JOG CW” and “JOG CCW”. Activating one of the inputs commands the drive to move the motor at a pre-designated speed until the contact is opened. A relay or mechanical switch can be used to activate the jog inputs. 5-24 volt circuitry can be used. The schematic diagram of the input circuit is shown below.

If you're using a switch or relay, wire one end to the JOG input and the other to the power supply negative (-) terminal. Then connect the COM input to the power supply positive (+) terminal.

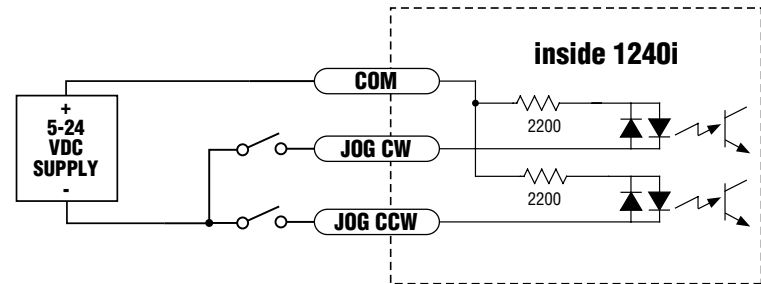

Limit Switches

The 1240i has two limit switch inputs, LIMIT CW and LIMIT CCW. By connecting switches or sensors that are triggered by the motion of the motor or load, you can force the 1240i to operate within certain limits. This is useful if a program error could cause damage to your system by traveling too far.

The limit inputs are optically isolated. This allows you to choose a voltage for your limit circuits of 5 to 24 volts DC. This also allows you to have long wires on limit sensors that may be far from the 1240i with less risk of introducing noise to the 1240i. The schematic diagram of the limit switch input circuit is shown below.

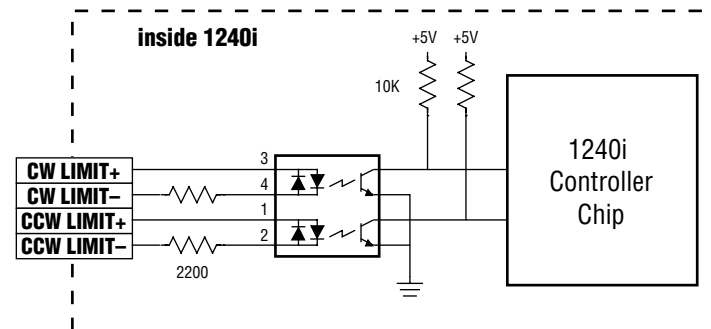

Wiring a Mechanical Limit Switch

You can use normally open or normally closed limit switches. Either way, wire them as shown here.

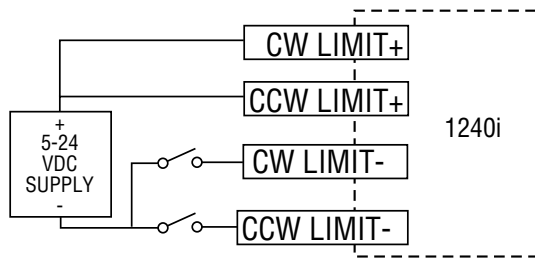

Wiring a Limit Sensor

Some systems use active limit sensors that produce a voltage output rather than a switch or relay closure. These devices must be wired differently than switches.

If your sensor has an open collector output or a **sinking** output, wire it like this:

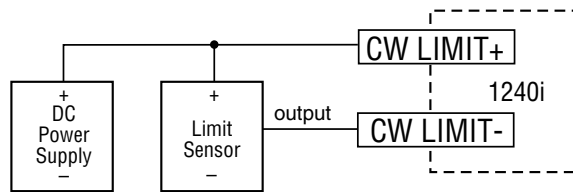

Wiring for Sinking or Open Collector Output

If the sensor output goes low at the limit, select the option “closed”. If the output is open, or high voltage, choose “open”.

Other sensors have **sourcing** outputs. That means that current can flow out of the sensor output, but not into it. In that case, wire the sensor this way:

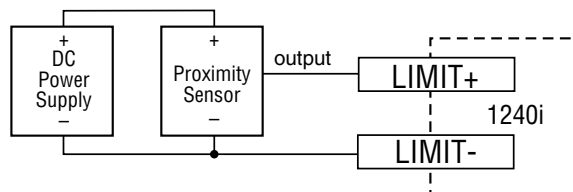

Wiring for Sourcing Output

If the sensor output goes high at the limit, choose the program option “closed”. If the output is low at the limit, select “open”.

Wiring Inputs

The 1240i input circuits can be used with sourcing or sinking signals, 5 to 24 volts. This allows connection to many TTL circuits, PLCs, relays and mechanical switches. Because the input circuits are isolated, they require a source of power. If you are connecting to an open collector TTL circuit or to a PLC, you should be able to get power from the PLC or TTL power supply. If you are using relays or mechanical switches, you will need a 5-24 V power supply. This also applies if you are connecting the 1240i inputs to another Si product from Applied Motion, like the Si-100 indexers or the 3540i, Si3540, Si5580, 7080i and Si4500 indexer-drives.

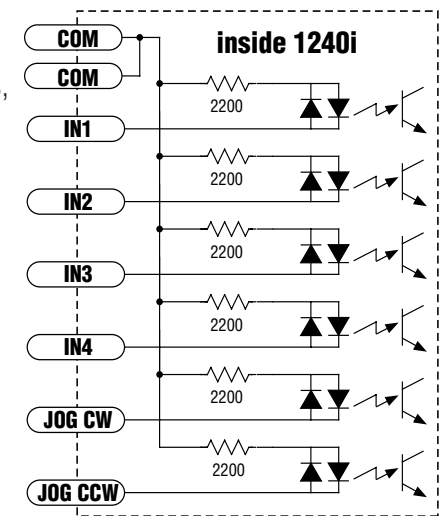

Note: If current is flowing into or out of an 1240i input, the logic state of that input is low. If no current is flowing, or the input is not connected, the logic state is high.

The diagrams on the following pages show how to connect 1240i inputs to various devices.

! The maximum voltage that can be applied to an input terminal is 24 volts DC. Never apply AC voltage to an input terminal.

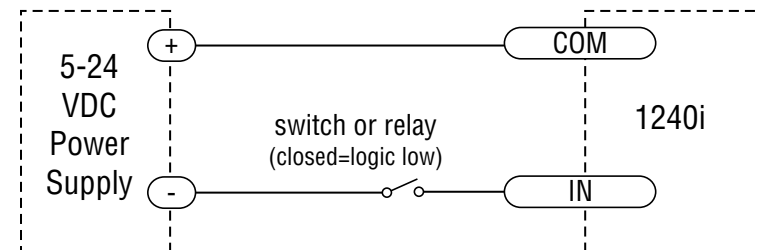

Connecting an Input to a Switch or Relay

Use normally open momentary switch to trigger 1240i using Wait Input instruction.

Use single throw switch for parameter selection using If Input instruction.

Use normally open momentary switch for jogging.

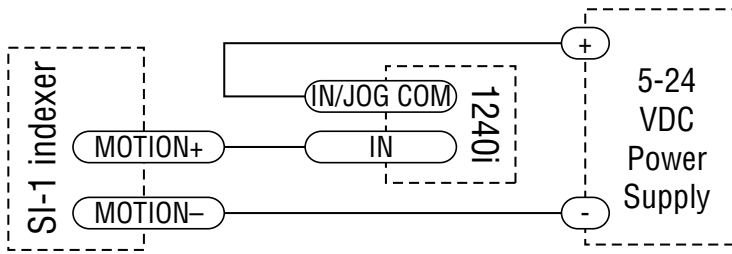

Connecting an Input to the Si-1 Motion Output

(Set Si-1 motion signal to "in position". Si-1 will trigger 1240i at end of each move).

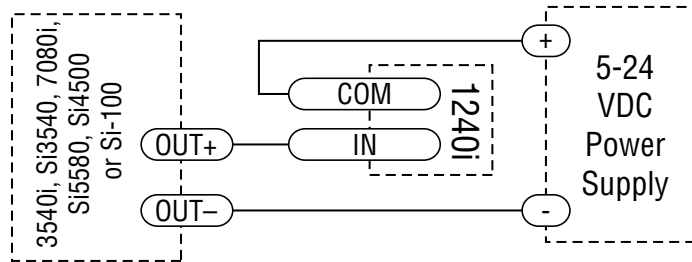

Connecting a 3540i, Si3540, Si5580, 7080i or Si4500

(When output closes, 1240i input goes low).

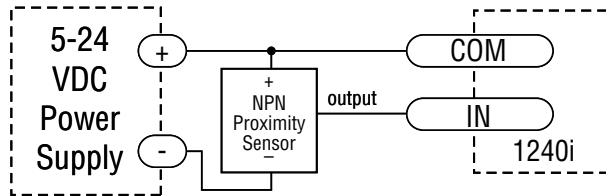

Connecting an NPN Type Proximity Sensor to a 1240i input

(When prox sensor activates, 1240i input goes low).

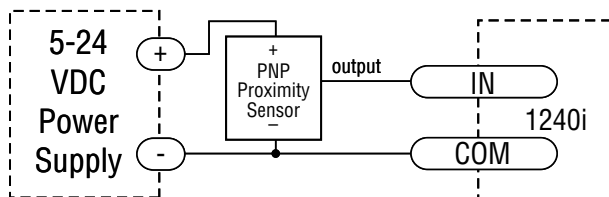

Connecting a PNP Type Proximity Sensor to a 1240i input

(When prox sensor activates, 1240i input goes low).

Wiring Outputs

Before we discuss the output conditions, we need to talk about the circuitry. All three 1240i outputs are optically isolated. That means that there is no electrical connection between the indexer-drive and the output terminals. The signal is transmitted to the output as light. What you "see" is a transistor (NPN type) that closes, or conducts current, when the output is "low". When the output is high, the transistor is open.

Note: At power-up, the 1240i sets all three programmable outputs high (open circuit).



The maximum voltage between any pair of + and - output terminals is 24 volts DC. Never connect AC voltages to the 1240i output terminals. Maximum current is 100 mA per output.

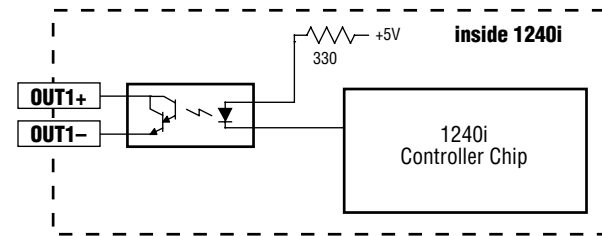

Schematic Diagram of 1240i Output Circuit

Since there is no electrical connection to the 1240i, you must provide the source of current and voltage, typically from a power supply. You must also limit the current to less than 100 mA so that the output transistor is not damaged. You would normally use a resistor for this, but some loads (such as PLC inputs) limit the current automatically.

The diagram below shows how to connect a 1240i output to an optically isolated PLC input.

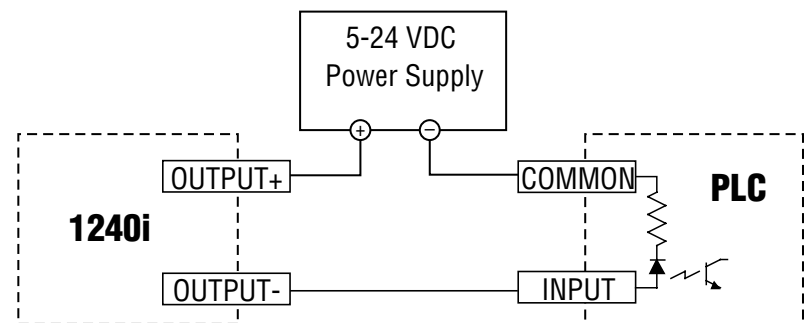

Microstepping

Most step motor drives offer a choice between full step and half step resolutions. In full step mode, both motor phases are used all the time. Half stepping divides each step into two smaller steps by alternating between both phases on and one phase on.

Microstepping drives like the 1240i precisely control the amount of current in each phase at each step position as a means of electronically subdividing the steps even further. The 1240i offers a choice of 13 step resolutions. The highest setting divides each full step into 254 microsteps, providing 50,800 steps per revolution when using a 1.8° motor.

In addition to providing precise positioning and smooth motion, microstep drives can be used for motion conversion between different units. The 25,400 step/rev setting is provided as a means of converting motion from metric to english (there are 25.4 mm in an inch). Other settings provide step angles that are decimal degrees (36,000 steps/rev makes the motor take 0.01° steps). Some settings are used with lead screws. When the drive is set to 2000 steps/rev and used with a 0.2 pitch lead screw, you get 0.0001 inches/step.

The microstep resolution of the 1240i is set by the Si Programmer™ software.

Mounting the Drive.

The 1240i has four 0.156 inch diameter holes in the circuit board for mounting. Always use standoffs or spacers to support the 1240i: a 1240i with power connected will be damaged if you set it on a conductive surface without supports. The standoffs or spacers can be up to 0.25 inch in outer diameter. You can use #4 or #6 screws to fasten the 1240i.

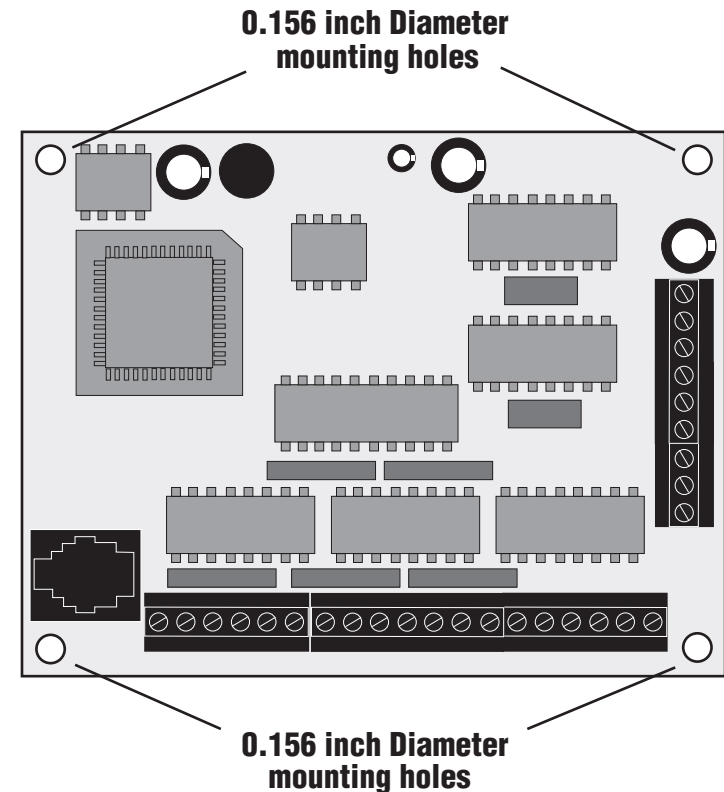

Mounting the Optional MMI

There are two ways to mount the MMI in your application. No matter which method you choose, you'll need to connect the MMI to your 1240i with the MMI cable. The MMI has the same telephone style connector as the 1240i.

Flush Mounting

When you remove the MMI from the shipping carton, you will notice that it has two parts. The first is a fairly thin section that contains the keypad, display and some circuit boards. The other part is thicker and contains the telephone jack and a cable that connects to the keypad assembly.

When you flush mount the MMI in a panel, only the thin section will stick out from your panel - the large portion mounts behind your panel. You'll need to cut a precise section from your panel. There is a cardboard template in the MMI's shipping box for this purpose.

If you want the MMI to be dust proof and watertight, you must place the black rubber gasket between the thin part of the MMI and your panel. Assemble the two halves using the eight small screws provided.

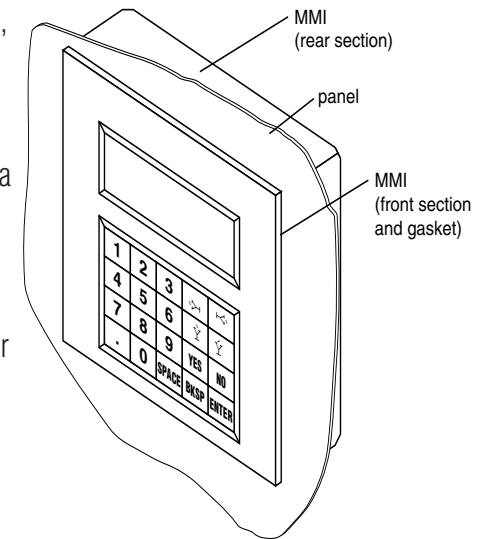

Surface Mounting

An easier way to mount the MMI is to bolt the two halves together ahead of time, using the eight small screws. If you want the MMI to be dust proof and watertight, put the black rubber gasket between the two halves before screwing them together.

Then cut a hole in your panel for the cable that runs between the MMI and the 1240i. The hole must be at least 5/8" in diameter for the connector to fit through. You will also need two holes that line up with the big mounting holes in the MMI. The mechanical outline on page 22 shows the location of the big mounting holes.

When you mount the MMI to your panel, you will need to use some kind of sealant to keep dust and liquid out. Silicone or latex caulking is okay, or you can make your own gasket from a sheet of compliant material like rubber or RTV.

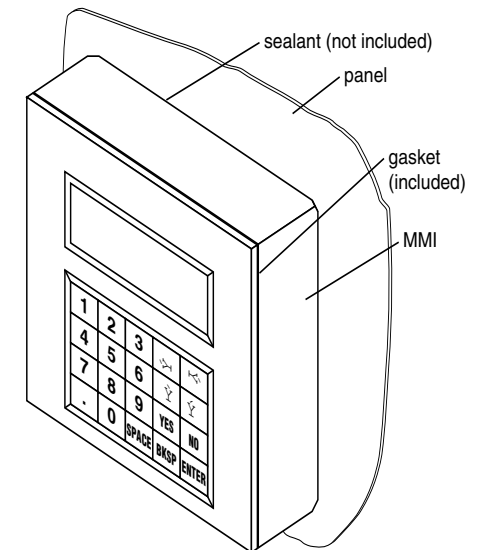

Recommended Motors

Motor Number	Winding Connection	Max Torque oz-in	Current Setting Amps/phase
HT11-012	series	7	1.0
HT11-013	series	10	1.0
5014-842	series	19	1.0
HT17-068	parallel	22	1.2
HT17-072	parallel	32	1.1
HT17-076	parallel	52	1.1
HT23-393/593	parallel	45	1.2
HT23-396/596	parallel	115	1.2
HT23-399/599	parallel	170	1.2

Mechanical Outline

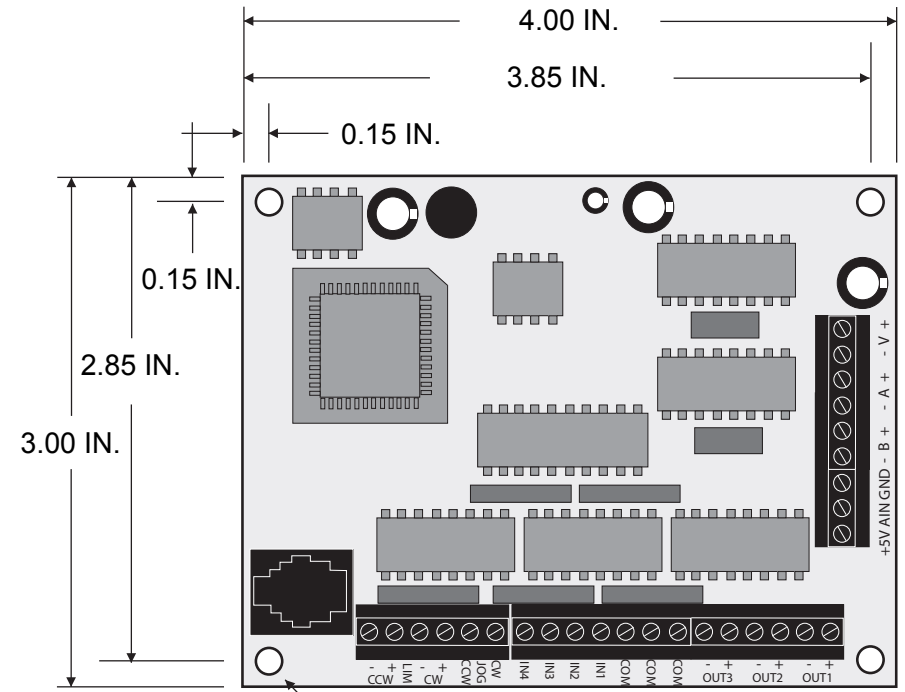

4 HOLES, 0.156 DIA.



Technical Specifications

Amplifiers Dual H-bridge, 3 state, pulse width modulated (PWM) switching at 25 kHz. 0.1 - 1.2 amps/phase output current, software selectable. 48 watts maximum output power. Automatic idle current reduction (software programmable) reduces current to motor when idle. Minimum motor inductance is 0.8 mH.

Power Supply Accepts 12 - 42 VDC power supply. 1.2 amps or greater at 24VDC.

Inputs 5 - 24 VDC, optically isolated. 2200 ohms internal resistance. Can be configured for sinking (NPN) or sourcing (PNP) signals.

Analog Input - not currently supported by Si Programmer, may be read in SCL mode using "RA or "IA" commands.

Outputs Optically isolated. 5-24 VDC, 100 mA max.

Microstepping 13 software selectable resolutions. Steps per revolution with 1.8° motor: 2000, 5000, 10000, 12800, 18000, 20000, 21600, 25000, 25400, 25600, 36000, 50000, 50800. Waveform: pure sine.

Motion Update 12800 Hz.

Physical Constructed on 0.063 inch thick printed circuit board. Four mounting holes, 0.156 inch diameter. Overall size : 3.00 x 4.00 x 0.65 inches. 0.15 lb. 0 to 50°C ambient operating temperature. See page 20 for detailed drawing.

Connectors European style screw terminal blocks. Power Supply and Motor: 6 position. Wire size: AWG 16 - 28. Signal input/output: 19 position. Wire size: AWG 16 - 28.

Agency Approvals CE compliant to EN55011A, EN50082-1(1997)

Mechanical Outline - Optional MMI

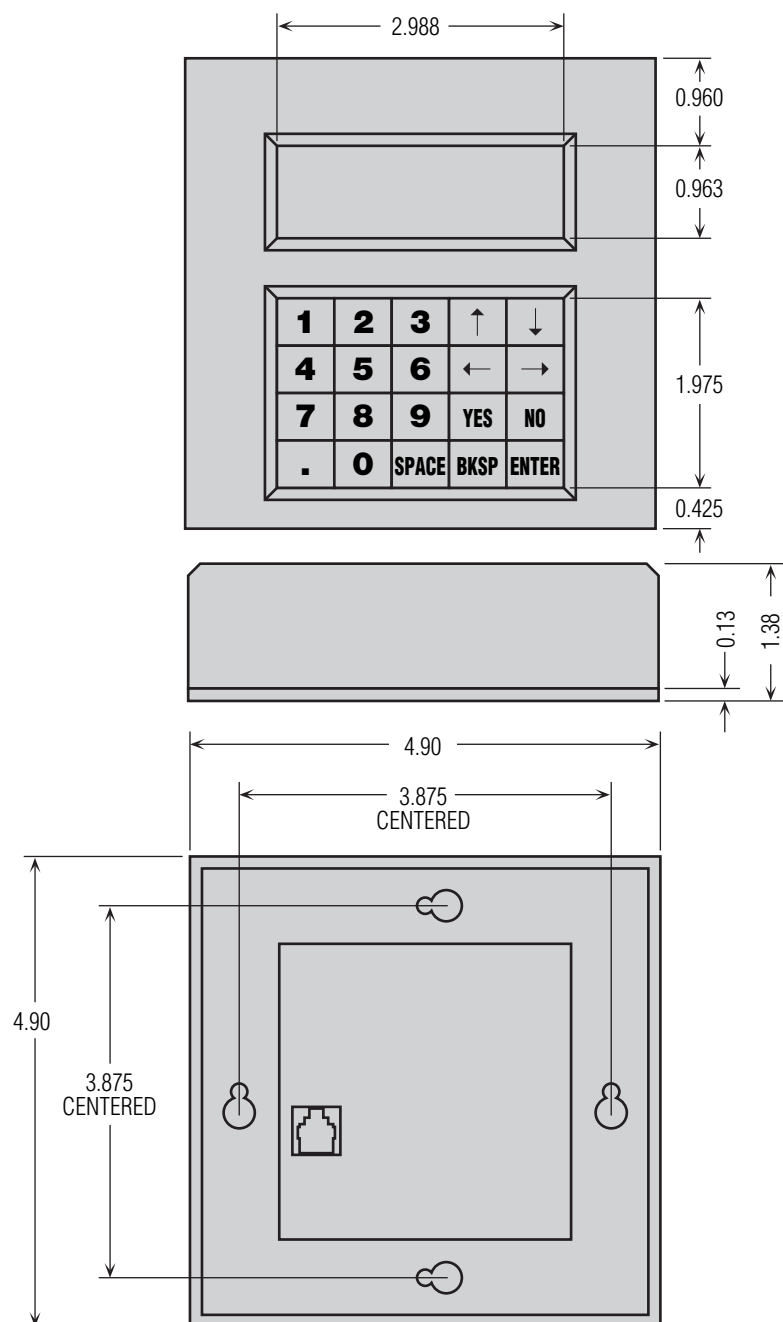

Applied Motion Products, Inc.

404 Westridge Drive Watsonville, CA 95076

Tel (831) 761-6555 (800) 525-1609 Fax (831)-761-6544

<http://www.applied-motion.com>

Copyright 2000